

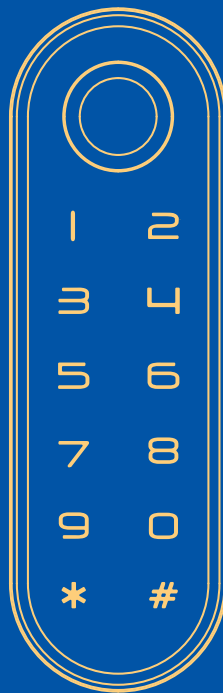

SMART FURNITURE LOCK

PROTECTING WHAT MATTERS



SMART FURNITURE LOCK DRAWER/CABINET LOCK



SCL10

- Fingerprint capacity: 10
- Unlocking Methods: Fingerprint & E-Key
- 3*AAA Alkaline battery / Low voltage alert / Emergency power supply
- Material: ABS
- Color: Black
- Usage scenarios: Drawer, cabinet wardrobe, etc

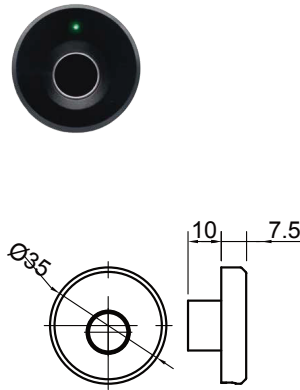

SCL20

- Fingerprint capacity: 20
- Unlocking Methods: Fingerprint & E-Key
- 3*AAA Alkaline battery / Low voltage alert / Emergency power supply
- Material: Zinc Alloy
- Color: Black
- Handle design
- Usage scenarios: Drawer, cabinet wardrobe, etc



SCL30

- Fingerprint capacity: 20
- Unlocking Methods: Fingerprint & E-Key
- 3*AAA Alkaline battery / Low voltage alert / Emergency power supply
- Material: ABS
- Color: Black
- Handle design
- Usage scenarios: Drawer, cabinet wardrobe, etc

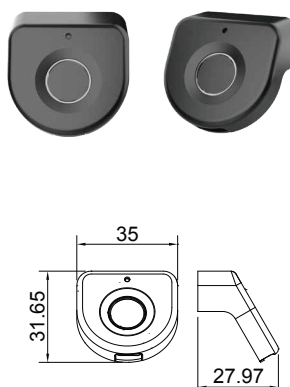

SMART FURNITURE LOCK DRAWER/CABINET LOCK

SCL40

- Fingerprint capacity: 20
- Unlocking Methods: Fingerprint & E-Key
- 3*AAA Alkaline battery / Low voltage alert / Emergency power supply
- Material: Zinc Alloy
- Color: Black/Grey
- Handle design
- Usage scenarios: Drawer, cabinet wardrobe, etc

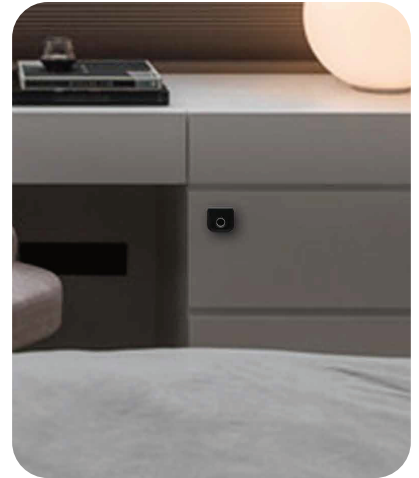
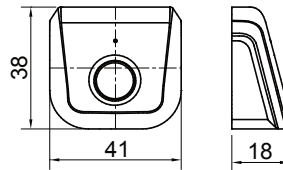

SCL50

- Fingerprint capacity: 20
- Unlocking Methods: Fingerprint & E-Key
- 3*AAA Alkaline battery / Low voltage alert / Emergency power supply
- Material: Zinc Alloy
- Color: Black
- Handle design
- Usage scenarios: Drawer, cabinet wardrobe, etc

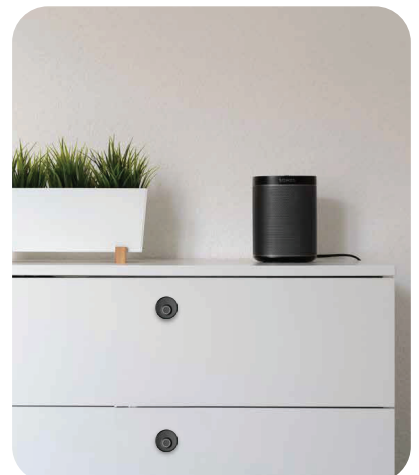
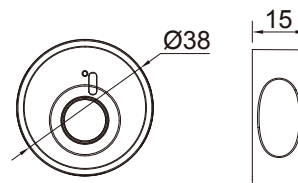

SCL60

- Code: management & user
- Unlocking Methods: Password & E-Key
- Mode: Auto / Manual / Public
- 3*AAA Alkaline battery / Low voltage alert / Emergency power supply
- Material: ABS
- Color: Black
- Handle design
- Usage scenarios: Locker, drawer, cabinet wardrobe, etc

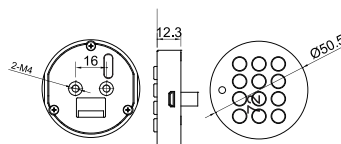

SMART FURNITURE LOCK DRAWER/CABINET LOCK



SCL70

- Unlocking Methods: Password & Fingerprint & E-Key
- Code: management & user
- Fingerprint capacity: 100
- Mode: Auto / Manual / Public
- 3*AAA Alkaline battery / Low voltage alert / Emergency power supply
- Material: ABS
- Color: Black
- Handle design/ Multiple colour indicator
- Usage scenarios: Locker, drawer, cabinet wardrobe, etc

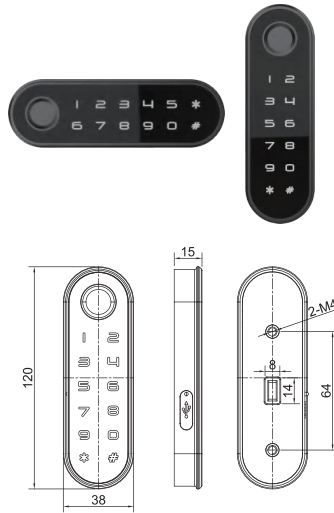

SCL80

- Hidden RFID Lock
- Mifare 1 Card: 1 Management card & 14 Users
- Function: NFC/Bluetooth, Automatic pop-up
- 3*AAA Alkaline battery / Low voltage alert / Emergency power supply
- Material: ABS
- Color: Black
- Usage scenarios: Locker, drawer, cabinet wardrobe, etc

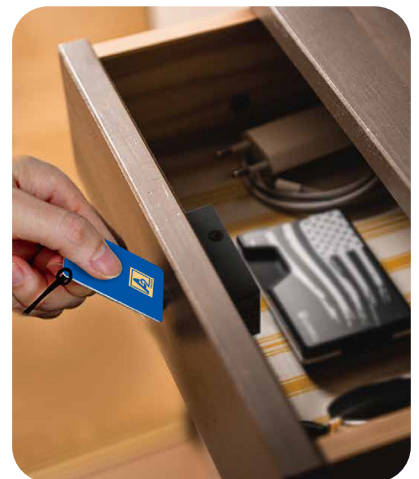
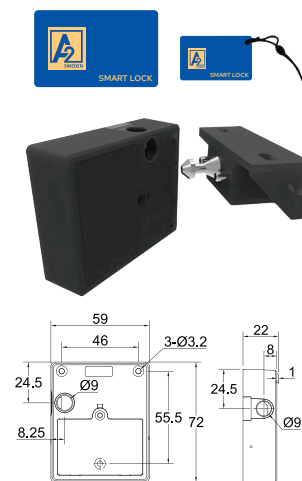
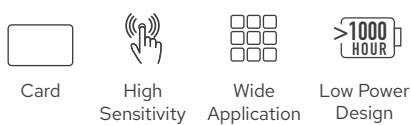

SCL90

- Unlocking Methods: Password & Fingerprint & E-Key
- Code: management & user
- Fingerprint capacity: 100
- Mode: Auto / Manual / Public
- 3*AAA Alkaline battery / Low voltage alert / Emergency power supply
- Material: Aluminum + Acrylic
- Color: Black/Gold
- Handle design/ Multiple colour indicator
- Usage scenarios: Locker, drawer, cabinet wardrobe, etc

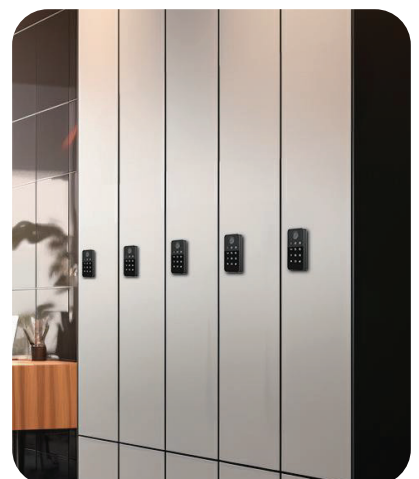
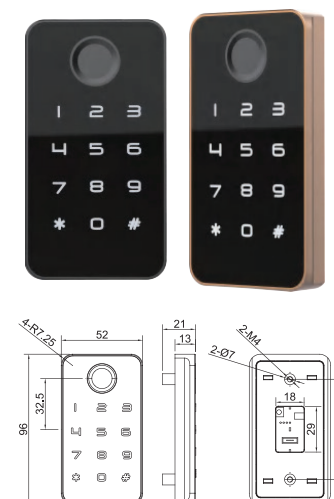
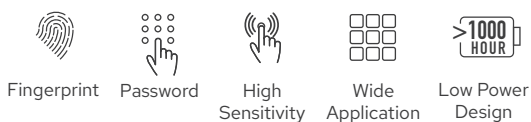



SWEDEN

A2 Building Solutions AB
Stora Väsby, Upplands Väsby
Sweden 19437

DUBAI

A2 Building Solutions
Unit 3509, 35th Floor,
Burlington Tower, Business Bay,
Dubai, UAE
P.O. Box 417764

INDIA

A2 Building Solutions India Pvt. Ltd.
6th Floor, Good Earth Business Bay-1,
Sector-58, Gurgaon

**SMART FURNITURE
LOCK**