



A2 HERMOSA Smart Lock

Move to smarter ways to open the door. Hermosa Smart Lock allows you to access the door via face recognition, fingerprint, PIN, card or simply A2 Smart Living App.

Bring home the latest in technology and best in class features from A2. Designed to elevate your lifestyle with convenience. Ravishing design for your safety and security.



Face Scan



Fingerprint



Card



PIN Code



Mobile App



Mechanical
Key

A2 HERMOSA Smart Lock



Champagne Gold



Hidden Fingerprint Design
easy to unlock with one grip



Privacy Mode



Matte Black













High Security Cylinder



Emergency Power
Mechanical Key

Smart Features

-  Single Push Action
-  Built-in Doorbell
-  High Security Mortise Lock
-  Privacy Mode
-  Dual Authorisation Mode
-  Security Alarms
-  Low Battery Alarm
-  Emergency Power
-  Indicating Light
-  English Voice Prompt

Face Recognition	Up to 20
Fingerprint	Up to 100
PIN Code	Up to 20
IC Cards	Up to 100
Mortise Lock	Silent Lock, High Security SS 304
Mechanical Key	2 Nos
Main Body	76(W) x 420(H) x 25(D)mm
Back Body	75(W) x 420(H) x 41(D)mm
Backset	60mm
Battery	1PCS 5000Mah Lithium Battery + 4PCS AA Alkaline Batteries
Emergency Power	5V Type C
Color	Champagne Gold Matte Black

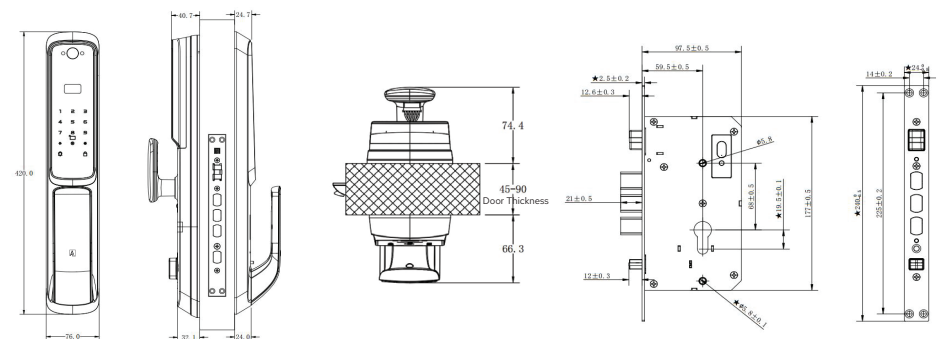



SWEDEN

A2 Building Solutions AB
Stora Wäsby, Upplands Väsby
Sweden 19437

DUBAI

A2 Building Solutions
Unit 3509, 35th Floor,
Burlington Tower, Business Bay,
Dubai, UAE
P.O. Box 417764

INDIA

A2 Building Solutions India Pvt. Ltd.
Unit No. 603 & 604,
Welldone Tech Park, Sector 48,
Gurugram, Haryana

SMART LOCKS