



A2 VISO+ AUTOMATIC PUSH PULL SMART LOCK USER MANUAL

- Palm Vein
- Visual Camera
- Face Recognition
- Fingerprint
- Password
- Card
- Mobile APP
- Mechanical Key

Please register the admin users in time.
Ensure not to use consecutive repetitive numbers for your safety.

Safety Cautions

- The manual should be read thoroughly before operating the product.
- Please use a soft cloth to clean the lock and not wipe this product with water, benzene, alcohol, or corrosive substances.
- Do not exert excessive force or use sharp tools to press the fingerprint zone.
- When unlocking the door to hear "Dry Battery Low", please replace all dry batteries at once to avoid mixing new and old batteries.

Product Components

A Mortise lock	B Strike plate	C Outside panel	D Inside panel	E Inside cover plate	F Retaining stud, screw F1: Door thickness 35-45mm M5×35 M5×25 F2: Door thickness 46-55mm M5×35 M5×35 F3: Door thickness 56-70mm M5×35 M5×50 F4: Door thickness 71-90mm M5×60 M5×50
G Cylinder	H Cylinder screw M5X70	I LR6 Alkaline battery (Optional)	J Machine screw M4×12	K USB Cable	L Positioning columns
M key	N Self-tapping screw	O Lithium battery			

Installation Axial View (right-handed door)

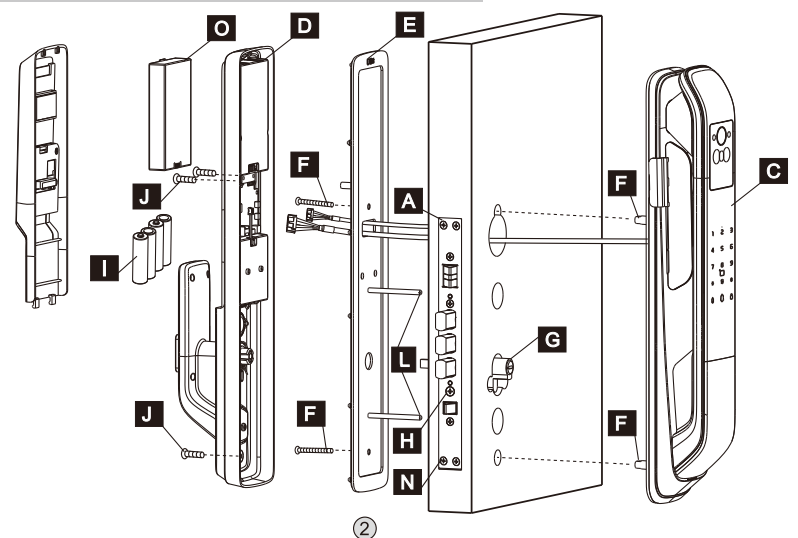

Mortise Lock Direction Chagement Description

- If the bevel of the tongue is not facing the direction of the door closure, please follow the steps below for adjustment.
- ①Remove the screws and guide plate;
 - ②Press into the latch bolt;
 - ③Flip open the noise-reducing flap;
 - ④Take out the latch bolt and rotate it 180°;
 - ⑤Press it into the mortise lock again;
 - ⑥Install back the noise-reducing flap and install the guide plate again.

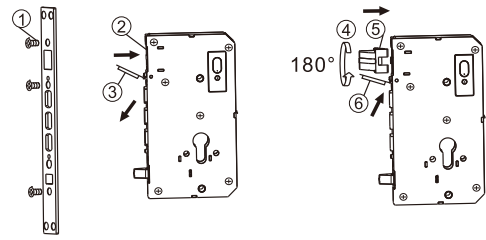

Installation Steps (right-handed door)

Marking and Drilling

Marking and drilling holes on door leaf and frame according to installation drawing

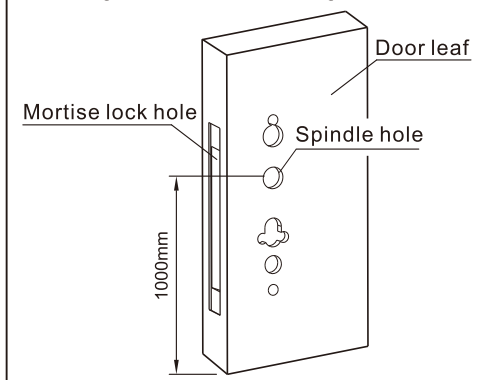

Install mortise lock

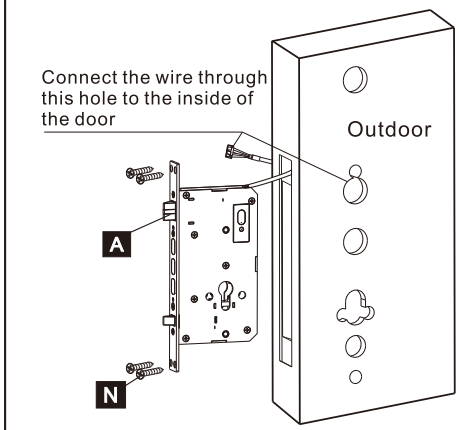

Install spindle, cylinder

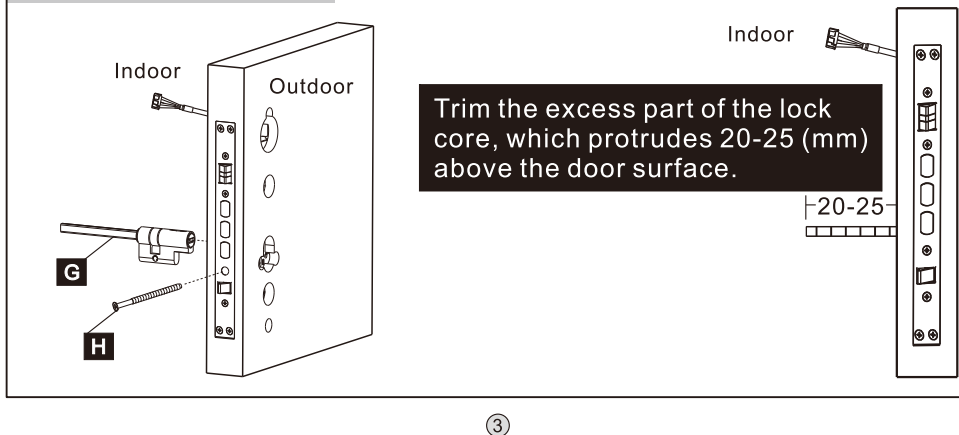

Install the inside cover plate

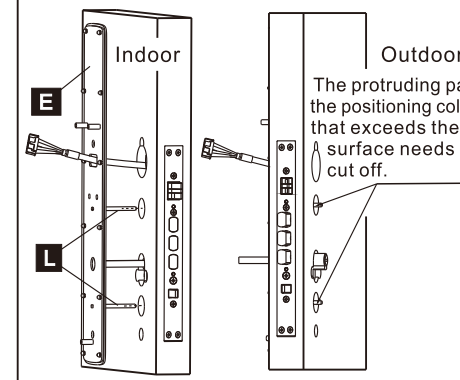

Install the outside cover plate

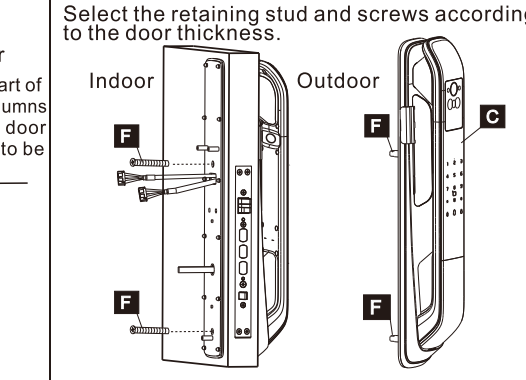

Install the inside panel

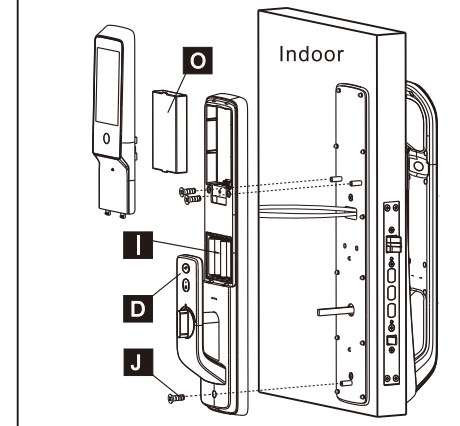

Installation Result

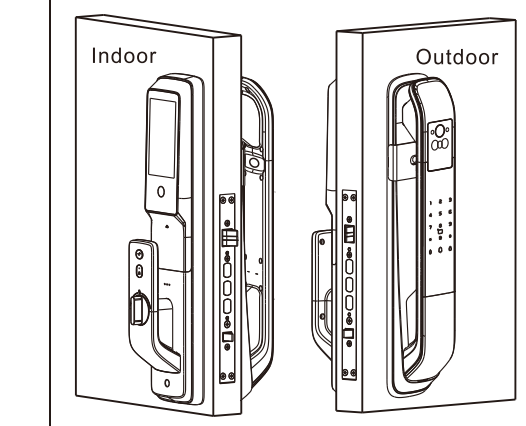

Install strike plate

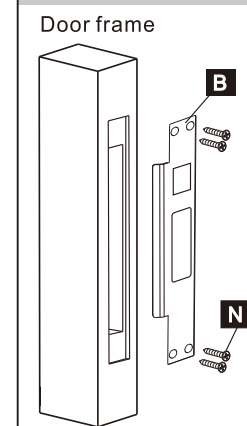

Install the anti-pinch hand guard

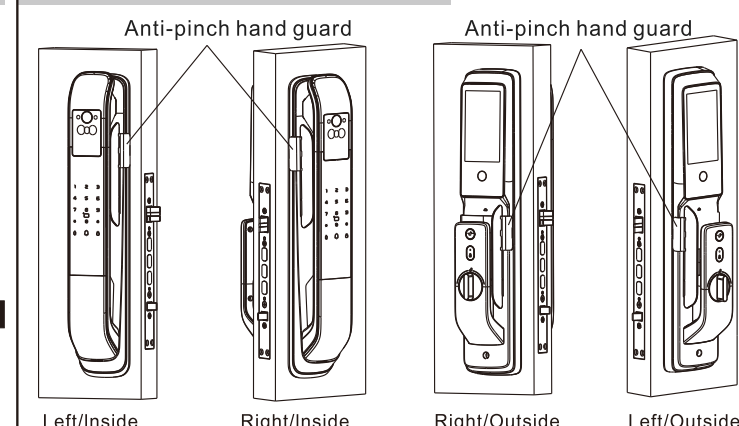

Product Specification

Unlocking Way: Palm Vein/Face/Fingerprint/Password/Card/Key/Mobile App
 User Capacity: 20PCS Palm/20PCS Face/100PCS Fingerprint /20PCS Password/100PCS IC Card
 User Management: Via APP
 Visual Camera: Yes
 Wide-angle Lens: 150°
 IPS Display: 4.5 Inch
 Camera Pixel: 1.0 Million
 Dual Verification: Yes
 Mortise Lock: D6068 or D7068 Automatic
 Power: 4.6V-8.4V (4PCS LR6 AA Alkaline batteries+1PCS 5000mAh Lithium battery)
 Emergency Power Supply: Type-C
 Working Temperature: -25°C - + 70°C
 Humidity: 20% -95%
 Door Thickness: 35-45mm 46-55mm 56-70mm 71-90mm

Power System

This model is powered by 1pc 5000mAh Lithium rechargeable battery and 4 pcs backup alkaline batteries.

- Lithium Battery: Supports all functions including face recognition, visual camera, fingerprint, password, card and App functions.
- Alkaline Battery: Supports fingerprint, password, card and normal lock functions.

Note: Lithium battery can be charged via Type C charger with local plug standards. Green indicator on the battery will indicate full charge while the battery can be re-charged >300 times.

Green indicator: the battery is fully charged.

Graphic Description

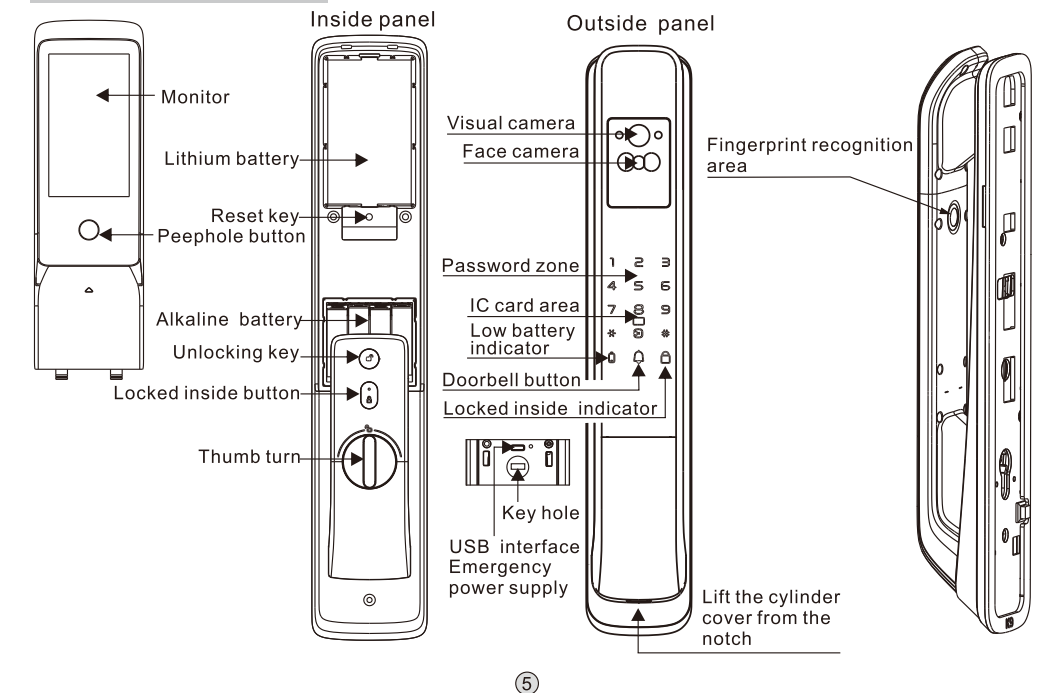

Door lock Initialization

- 1.Remove the battery box cover from the inner panel.
- 2.Keep pressing the resetting button with 5 time beeps and voice prompt "press # key to confirm initialization, press * key to exit, press 0 to repeat".
- 3.Press "# key to confirm, initialization succeed.

Note: After initialization, the lock would be under demo mode while any palm/face/fingerprint/ password/card can unlock it.

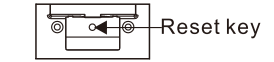

Demo Mode

Under demo mode, any palm/face/fingerprint/password/card can unlock the door.

First Admin Password Adding

Press "*" and "#" to enter the system setting, input same password twice and press "#" to save.
 Note: Please keep the unique admin password carefully for App adding.

Mobile APP Download

Download "A2 SMART LIVING" from APP Store or Google market, open the APP and register the user via Email or Mobile number.

Lock Adding Instruction:

1. Press "*" and "#" and input the first admin password enter the system setting menu.
2. Turn on mobile bluetooth function and connect to the Internet.
3. Open mobile APP and the phone would search available bluetooth devices automatically. If failed, press "+" to "Add devices" manually.
4. Configure the available internet and input the password to bind.
5. Rename the devices and save.

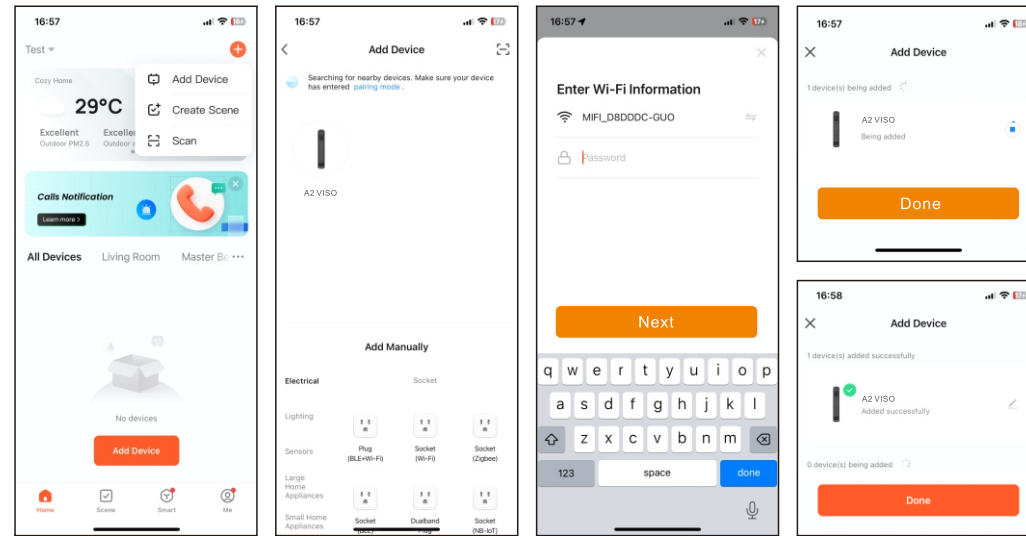

Note: a. Need to verify the admin user when adding the lock to App.
 b. The battery cover should be installed on the lock during APP operation.

Member Management

- I. Click "Member Management" button, and select related user ID you prefer to add new palm/face/fingerprint/password/card. The lock would enter user adding process directly.
 - II. Click "+" to add new Family member, input the registered user account ID to authorize the member as "Administrator" or "Normal Member".
- Note: a.Except the first admin password , all other users only can be registered via APP.
b.For palm/face/fingerprint/card registration, you need to register them on lock via APP management.

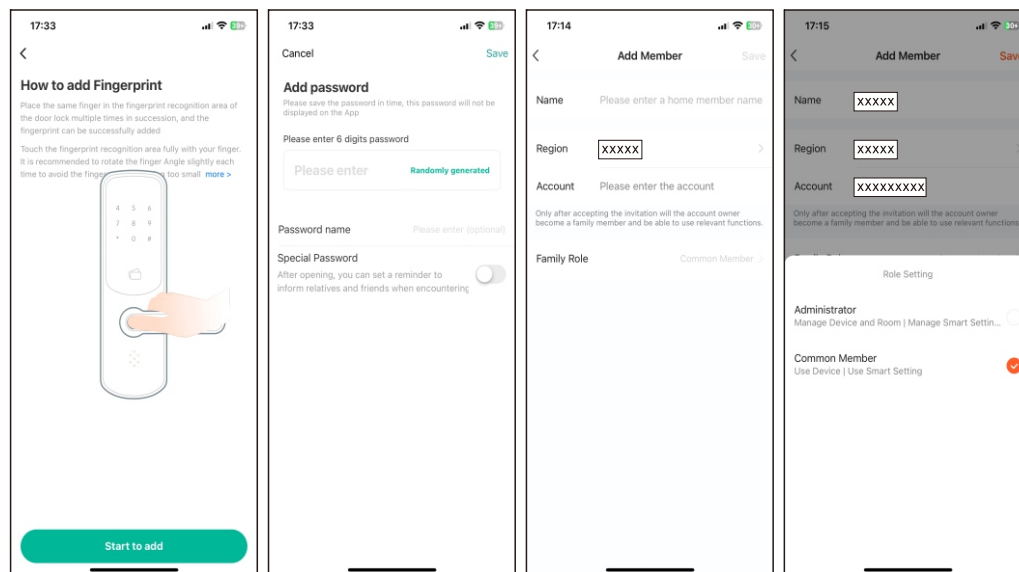
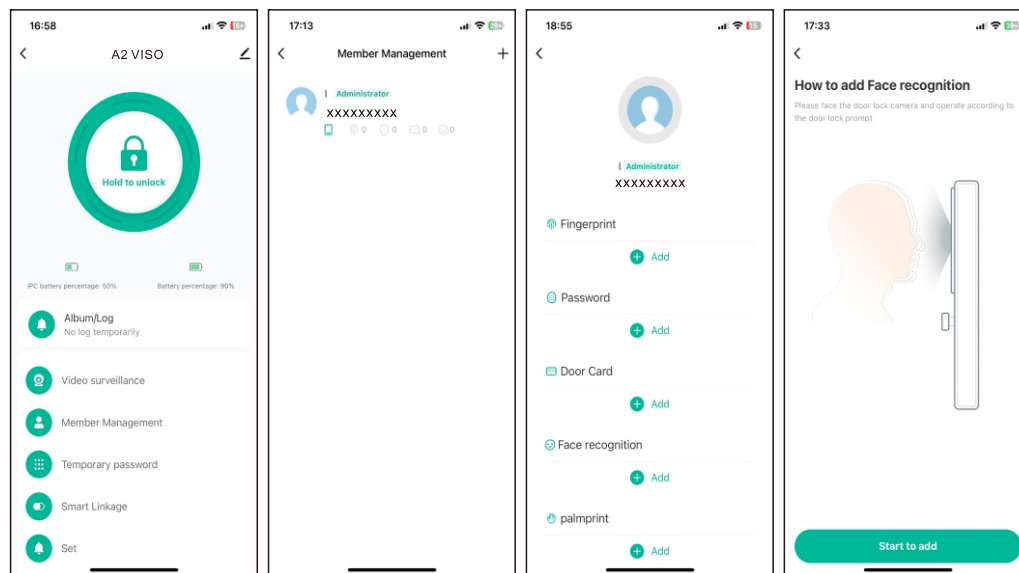

Temporary Password

You can generate dynamic or customized password based on requirements.
Note: Once the lock is added to the APP, the lock time would be synced with the phone's.

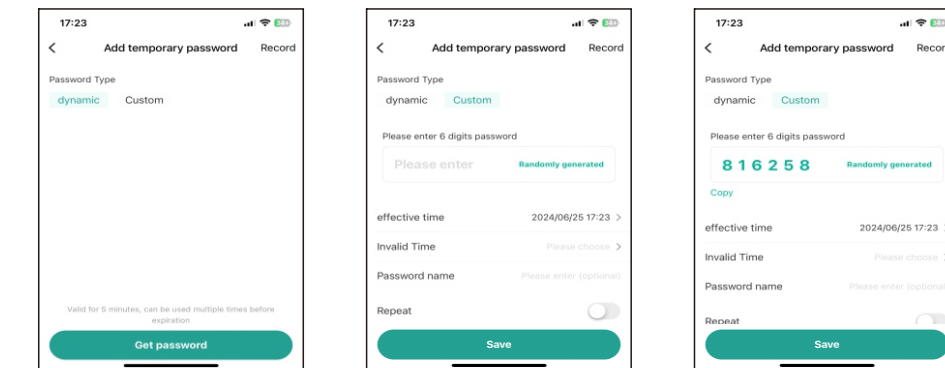

Video Surveillance

Click "video surveillance" to enter the visual camera to monitor outside.

- a. Keep pressing the "📹" icon to unlock the door remotely .
- b. Keep pressing the "🗣️" to talk and you can change the accents based on requirements.

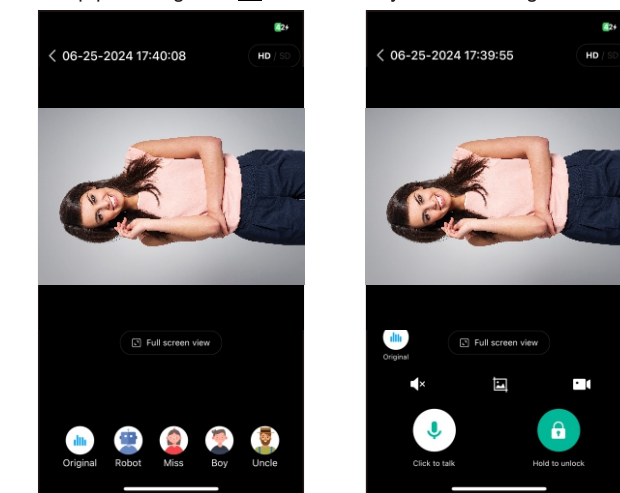

Smart Linkage

2 ways for smart home configuration, configure it based on the requirements.

- Option 1. Select "Smart Scenes" - "Custom Linkage Type"- "When lock status changes" - Select face/fingerprint/password/card unlocking as trigger condition - Select ">" and "=" and save configuration.
- Option 2. Select "Smart Scenes" - Select "Family go home" - Select "Family member" that you prefer to configure as trigger condition.

- Note: I. For 1th, all registered palm/face/fingerprint/password/card can be regarded as "Trigger condition" separately.
II. For 2th, all registered palm/face/fingerprint/password/card (sorted to the family member) can be regarded as "Trigger condition".

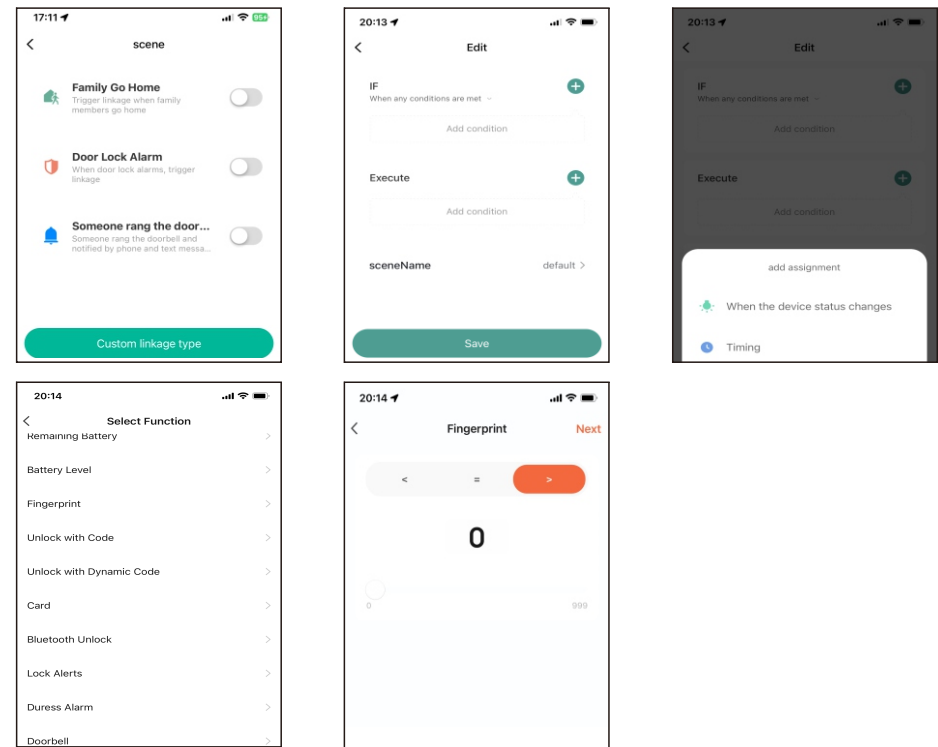

More Functions

message

Camera Setting
Select "One-Way Communication" or "Two-Way Talk" based on the actual situation and environment.

Remote Unlock
Once enabled, you can keep pressing "🔒" to unlock the door remotely via internet.

Permission Setting
Authorize the permission to all users or only the admins based on your requirements.

Multiple Authentication
Once enabled, you must complete 2 unlocking methods to unlock the door, such as fingerprint+ code, fingerprint+ card, fingerprint + face or code +card.

Home Deployment
Once enabled, an alert is triggered if the door is unlocked from the inside.

Navigation Volume
Modify the navigation volume based on your requirements.

Mute Mode Switch
After unlocking, the lock would be in silent mode for a specific period.

Passage Mode
After verification without unlocking the door, input "123" + "#". After that, the door would be not locked.

Note:a.Under passage mode, keep pressing "#" key or any digits to unlock the door directly without verification.
b. After palm/face/password/fingerprint/card verification, the passage mode would be cancelled.

Dormant Mode
To save power , you can open the dormant switch and set sleep time based on your requirements.

Note: Under dormant mode, remotely unlocking , remote monitoring and some other functions on APP would not work unless someone wake up the lock locally.

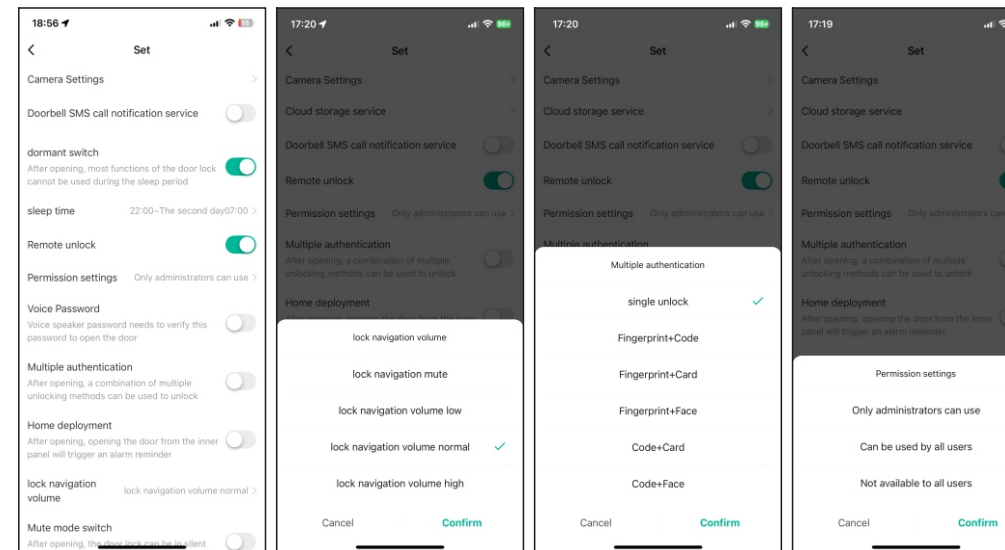

Alarming Information

Latch Tongue Get Stuck

When closing, the lock would make alarming if the latch or bolt does not release correctly.

Door Is Not Closed

If the door is not closed in 10 seconds after unlocking, a prompt and report will be sent.

Anti-pry Alarm

An alarm is generated and reported when the front panel is damaged or anti-pry button is pressed.

Low Battery Alarm

An alarm is generated and reported when the alkaline battery voltage is lower than 4.8V or lithium battery lower than 6.9v.

Arm Alarm

When someone unlock the door from inside, the lock would make alarm and sent notification to your APP.

Consecutive Wrong Verification

After 5 times wrong verification, the lock would make alarming. After 3 times wrong attempts, local notification would appear.

Linger Alarm

When the door is closed, the lock would make alarming if someone stay in front of the lock more than 10s.

Mortise Unlocking Failure Alarm

When the door is opened, the door lock detects that the mortise components are not properly executed, an alarm is generated and reported.

Mortise Locking Failure Alarm

When the door is closed, the door lock detects that the mortise components are not properly executed, an alarm is generated and reported.

Special User Unlocking Alarm

Setting the key as one hijacking key via APP, App notification would be triggered when this special key is verified.

Daily Operation

Indoor Locking

Auto locking: The lock would lock automatically after closing the door or when the sensor latch is pressed.

Locked Inside Function: Keep pressing the "Locked inside" button more than 3s until red light on.

Indoor Unlocking

Electronic unlocking: press the "unlocking" button, push/pull to open the door.

Mechanical Unlocking: Turn the thumb turn, and push/pull to open the door.

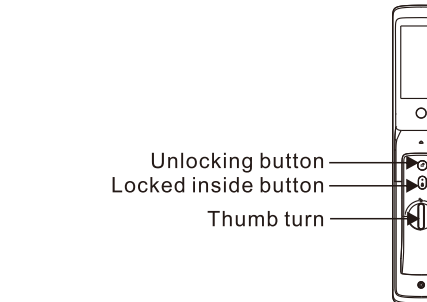

Caution: Be careful not to pinch your hand while using.

Outdoor Locking

Auto locking: The lock would lock automatically after closing the door or the sensor latch is pressed.

Outdoor Unlocking

1. Palm Vein: Put your palm front of camera with 20-50cm distance, push/pull to open after verification succeed.
2. Face: Approach the door lock, when the camera area flashes red, look squarely, push/pull to open the door after verification.
3. Fingerprint: put your finger onto the fingerprint sensor, push/pull to open the door directly after verification.
4. Password: Input 6-digit password, press # key to confirm and then to push/pull open the door directly.
5. IC card: Swipe the card on the card reader zone, push / pull to open the door after verification.
6. Mechanical Key: Insert the mechanical key and rotate, push/pull to open the door.
7. Keep pressing "🔒" to unlock the door remotely via the "Video Surveillance" page.

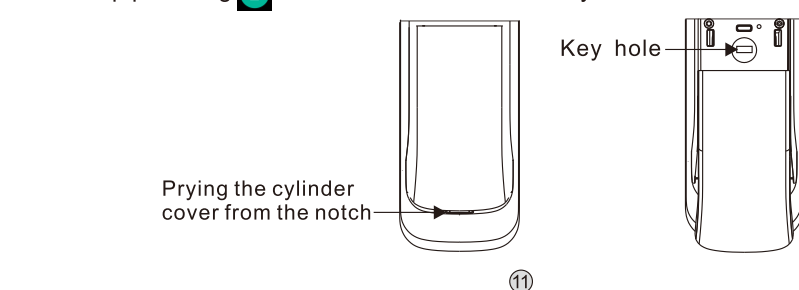

Trouble Shooting

Symptoms of malfunction	Possible analysis	Solution
Cannot open and close the lock normally	1.Improper installation causing the latch to be pressed against the door frame; 2.Door sagging or deformation causing the latch to be pressed against the door frame; 3.When locking the door, it may not be completely closed or a voice prompt indicates a locking failure.	1.Adjust the gap between the latch and the door frame; 2.Adjust the door; 3.Close and lock the door again.
Low battery voltage, please replace in time.	Dry battery power is insufficient	Please replace the new battery in time
Lithium battery voltage, please charge in time	Lithium battery power is insufficient	Please charge in time
Face function not work	Not installed lithium battery	Please install lithium battery
Face verification failed	1.The face has this block; 2. Not at the appropriate distance / not facing the camera.	1.Remove the cover; 2.50-80cm in front of the door lock, facing the camera.
Fingerprint verification failed	1. The fingerprint is not registered; 2. The finger is too dirty or wet; 3. The finger is too dry; 4. Finger position differs significantly from the registered position.	1. Use registered fingerprint; 2.Wipe your finger clean and try again; 3.Moisturize your fingers slightly and try again; 4.Try again with right position.
Lock does not work	1. Failing to work suddenly , it could be due to a system crash; 2. Always failing to work, it could be due to the battery power shortage .	1.Power the system through the USB interface to reboot; 2.Use power bank to power the system through the USB interface in the keyhole.
Lock emits a continuous alarm	1. Anti-pry function is triggered; 2. Arming mode alarm is triggered.	1.If the outer panel has not been pried, remove one battery to eliminate the alarm sound. Afterward, use a screwdriver to tighten the screws connecting the lower panel. Finally, reinstall the inner panel and the battery; 2.Verify the right fingerprint/password /card/face to open the door and disarm the arm mode.